

HEPA-filtered
VERDEdri®

Cleaner than Air™. Quieter than Before.



Put the hand drying experience first with the solution that delivers it all in one. The next-gen VERDEdri® leads in sanitation with hygienic technologies, efficiency, and sound quality.

Users can dry hands completely and confidently with touchless operation. **Cleaner than Air™** HEPA filtration captures 99.97% of particles, 0.3 μm or larger, cleaning the air before it reaches hands. The antimicrobial technology¹ helps maintain a cleaner environment.

Finally, we rounded off performance by cutting down on energy without tacking on time. Users dry their hands in as little as 12 seconds, while only using 3.16 watts-hrs². From there, we turned it down a notch. We refined acoustics 30%, while ensuring comfort.

VERDEdri has the upper hand with refined acoustics and superior features.



Hygienic Features

HEPA filter captures 99.97% of particles³. Antimicrobial technology protects the treated surfaces on the dryer by inhibiting the growth of bacteria, mold and fungus that can cause stains, odors or deterioration.



Energy Efficient

Optimized technology uses only 3.16 watt-hr per use and costs 32 cents for every 1,000 cycles.



Refined Acoustics

30% quieter⁴ sound level reduces volume for adjacent work areas or sensitive spaces.



ADA Compliant

Surface-mount installation and compact design ensure compliance for walkways and pathways.



Universal Voltage

Voltage now extends from 120-277V to adapt to any facility.



More Flexible

Sound control adjusts between three mode settings to accommodate sensitive spaces.



Extended Life

High-performance motor lasts 3 times longer than competing models.

HEPA-filtered VERDEdri®

Specifications

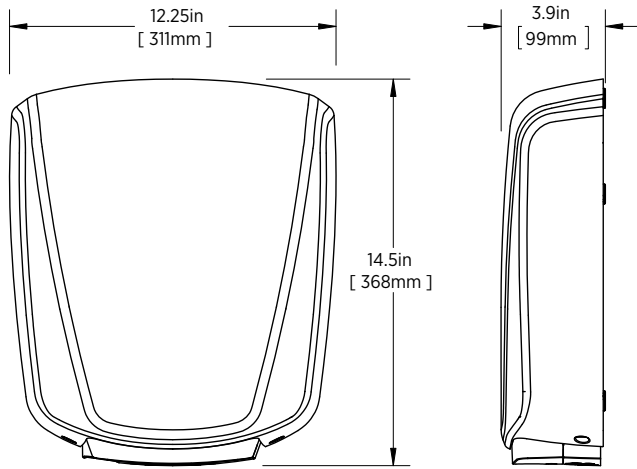

IP24



COVER MATERIAL	COVER FINISH / KIT	110-120 / 208 / 220-277 V	UNIT WEIGHT	SHIPPING WEIGHT	UNIT SIZE (HXWXD) INCH [MM]	SHIPPING SIZE (HXWXD) INCH [MM]
Aluminum	White	Q-974A2	8.3 lb / 3.7 kg	10.7 lb / 4.8kg	14.5" x 12.25" x 3.9" [368 x 311 x 100]	17.3" x 15.2" x 7.5" [440 x 385 x 190]
	Black	Q-162A2				
	Graphite	Q-962A2				
Stainless Steel	Polished	Q-972A2	9.9 lb / 4.4 kg	12.2 lb / 5.5 kg		
	Brushed	Q-973A2				
Optional Top Entry Adapter Kit	17-10310		3.8 lb / 1.7 kg	6.2 lb / 2.8 kg	16" x 13.8" x 1.2" [406 x 350 x 30]	16.9" x 14.8" x 3.5 [430 x 375 x 90]
HEPA Filter	93-10292K		0.4 lb / 0.9 kg	0.7 lb / 1.5 kg	9" x 3.3" x 3" [229 x 84 x 76]	9.4" x 3.5" x 3.5" [240 x 90 x 90]

	110-120 V	208 V / 220 - 240 V
Amps	8.3	4.1
Watts	950	950
Hz	50/60	50/60



Polished



Brushed



White



Black



Graphite

Sound Level: Sound at 79 in (2 m): 69 dBA measured in semi-anechoic chamber.

Choose a VERDEdri design for your restroom environment. World Dryer puts visionary products within arm's reach.

¹ Protects the treated surfaces on the dryer by inhibiting the growth of bacteria, mold and fungus that can cause stains, odors or deterioration.

² Dryers connected to 277 VAC use 3.83 watts-hrs per use.

³ 99.97% effective for particles 0.3 µm or larger.

⁴ Compared to prior VERDEdri models.

